

43	2	55253	CAP, PLASTC, 1" X 1"
42	1	21108	SPRING, RETURN, FOLDAWAY, DOWN/UP LOCK
41	1	21107	SPRING, RETURN, FOLDAWAY, UP/DOWN LOCK
40	1	99119	7/16" ID, 1" OD, 0.05" THICK NYLON FLAT WASHER
39	1	21477	PLASTIC CAP, TRUSS LEG LOCK
38	13	99118	BELLEVILLE WASHER, 1/2 ID X 1 OD
37	1	120396	1/2, WASHER, FLAT, SAE, ZP
36	2	35062	FLANGE BEARING,NYLON,8L,8F,TYPE 5,NYLINER
35	8	53960	HOOK / OYSTER / 2"
34	8	55859	SPRING
33	1	31347	FLEX-O-LATOR, BV
32	2	21214	RED PLASTIC COVER, 1/2 x 1/4 x 1
31	1	21210	GAS SPRING, 17" L, 6" STROKE, 600N
30	2	9422275	5/16-18UNC PREV TORQUE LOCK NUT, G5, ZP
29	2	21205	SHOCK MOUNT,BALL STUD,10MM, ZP
28	1	21213	RED PLASTIC COVER RECTANGLE
27	1	99091	7/16-14 X 1 1/8 SHOULDER BOLT
26	2	99015	7/16, WASHER, FLAT, USS, G8, ZP, YEL
25	4	120377	3/8-16UNC, HEX NUT, G5, ZP
24	4	180122	3/8-16UNC x 1 HHCS, G5, ZP
23	4	120382	3/8 LOCK WASHER, REG SPRING, ZP
22	2	55965	ROUND PLASTIC CAP
21	2	180124	3/8-16UNC x 1-1/4 HHCS,G5,ZP
20	3	99001	1/2-13UNC, CENTER LOK NUT, G5, ZP
19	1	21091	WELDMNT, LOCK MECH
18	1	21090	WELDMNT, LOCK MECH
17	1	21329	WELDMNT, TRUSS LEG LOCK
16	1	99530	NUT, ACORN, CENTER-LOCK, 8-32, GR-A, ZP
15	1	99500	8-32 x 1.25", PHIL, PAN HD, ZP
14	1	99113	COTTER PIN 3/16 X 2
13	1	31350	ROD, PIVOT, LOWER, BV
12	1	31334	TUBE, TRUNION, PIVOT, BV
11	1	31458	WLDMNT, DUMP MECH, III, BV, CS, WALL END
10	1	31452	ASSY, DUMP MECH, III, BV, CS
9	1	31470	VINYL BLACK, 33 1/2 x 18
8	2	55988-3	BUMPER PAD, POLYETHYLENE 1/8 x 1 x 2 5/8
7	1	21466	COVER, DUMP MECH. II, LAYOUT - CS
6	3	99117	PINE TREE CLIP, NYLON, 1/4 x 1 3/8, BLK
5	1	55713	LABEL ADHESIVE SEATBACK "CAUTION"
4	1	31313	WLDMNT, BACK, BV FLDWY, BENCH BACK
3	1	31320	WLDMNT, TRUSS, BV FLDWY, 2PL
2	1	31318	WLDMNT, SFRM, BV FLDWY, 2PL, CS
1	1	31310-1X	WLDMNT, FLRMNT, BV FLDWY, CS
ITEM	QTY	PART #	DESCRIPTION

P
P

NOT TO BE USED, DISCLOSED OR REPRODUCED WITHOUT PERMISSION.
PROPERTY OF FREEDMAN SEATING COMPANY.

REV.	DATE	ECN	DESCRIPTION	BY	CHKD.	APPD.
C	12/99	1867	ADDED ITEM 47, CHANGED SEAT BASE	ER		
D	1/01	2214	REVISED 31310 ITEM 4	TP		
E	1/03	2634	UPDATE BOM, ITM 5 VWs, ADD ITM 48, TYPOS PG 1	CL		
F	5/03	3186	ITEM 26 WAS 9413447	CL		
G	09/09	811	9500 WAS 99104; ADD 99501	SC		
H	05/12	892	REDRAWN IN SE, UPDATE BOM, NOTES, DESC, DIMS	NW	MK	DK
J	01/21/13	2140	UPDATED OBSOLETE PARTS IN MODEL, REVISED NOTES	EAR	MK	PV
K	08/29/13	3016	UPDATED 31318, 31458, 31452	EJ	SC	PV
L	03/10/15	4380	180122 WAS 180121; QTY 13 WAS QTY 1, 99015 WAS 120389			
			ADD 120396, 446363, 56510, 180145	JE	EJ	SC
M	11/10/15	5059	UPDATED BOM	JL	MK	SC
N	10/26/2016	5712	UPDATED BOM, REMOVED 52231463	SL	EJ	MK
P	8/29/18	7084	REPLACED 53962 WITH 53960, UPDATED QTY	SL	JL	MK

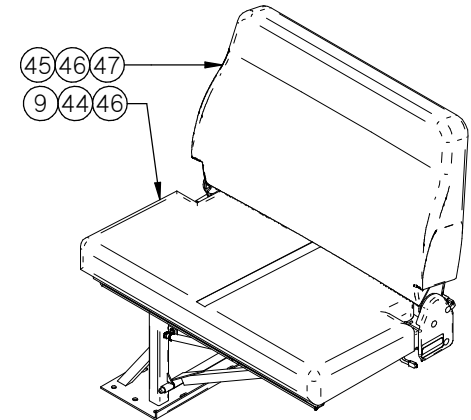
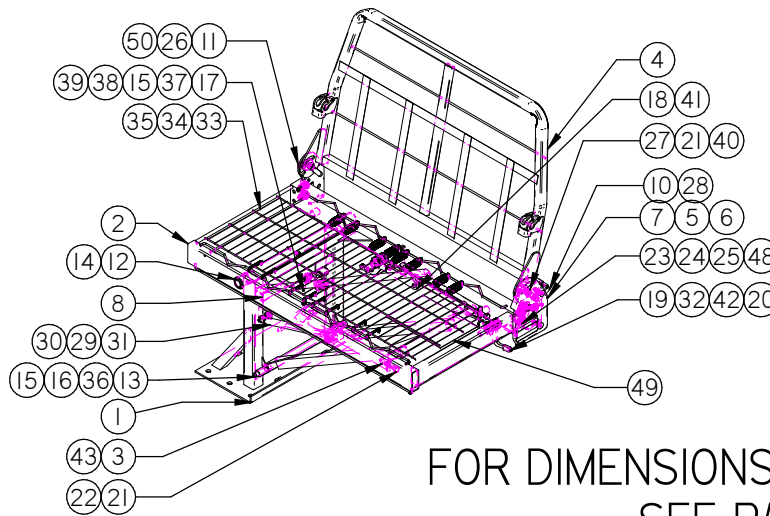

FOR DIMENSIONS AND SPECIFICATIONS,
SEE P/N 31301-X

NOTE(S)

- 1) ITEMS 1-4 & 44-48 ARE OPTION ITEMS SEE RELATED PRINTS FOR AVAILABLE OPTIONS.
- 2) FOR SEAT BACK OPTIONS SEE P/N 31300-GRAB ARMS.
- 3) FOR CHILD RESTRAINT OPTIONS SEE P/N 31300-CRS.
- 4) FOR TIE DOWN STORAGE OPTIONS SEE P/N 31300-TDSS.
- 5) FOR GRAB UNDER FOLDAWAY OPTIONS SEE P/N 31300-GUF.
- 6) FOR BIG VAN SHORT OPTIONS SEE P/N 31300-BVS.
- 7) FOR HI-BACK OPTIONS SEE 31300-HIBK-X.
- 8) APPROXIMATE SEAT WEIGHT IS 80 LBS.

Tolerances Unless Otherwise Specified:
Fraction: 1/X +/- 1/8"
Decimal: XXX +/- 0.02"
 X.XXX +/- 0.005"
Angular +/- 1 Degree
Unspecified Radii are 1/8"

DRAWING NAME: ASSY, SEAT, BV FLDWY, 2PL, CS		PROJECTION: 	
MATERIAL:	 Freedman Seating Co. 43415 W. Augusta Blvd Chicago, IL 60631		REF: _____ SUPERSEDES: _____
SPECIFICATION:	BY: DR DATE: 11/4/98 CHECKED: _____ APPROVED: _____	SIZE: C DRAWING No.: 31300-X	REV: P
SCALE: NOT TO SCALE	BOM	CODE	SHEET: 1 of 1