

56658

NOT TO BE USED, DISCLOSED OR REPRODUCED WITHOUT PERMISSION.
PROPERTY OF THE FREEDMAN SEATING COMPANY.

NOTES:

1. IF SEAT DOES NOT LOCK IN PLACE OR THERE IS SIGNIFICANT PLAY, ADJUST THE (2) 3/8-16 BOLTS AT THE END OF THE TRUSS RUNNERS.
2. IF SEAT IS NOT LOCKED IN POSITION, MAY CAUSE DAMAGE AND INJURY.

SEE NOTE 1
VIEW OF SEAT BOTTOM

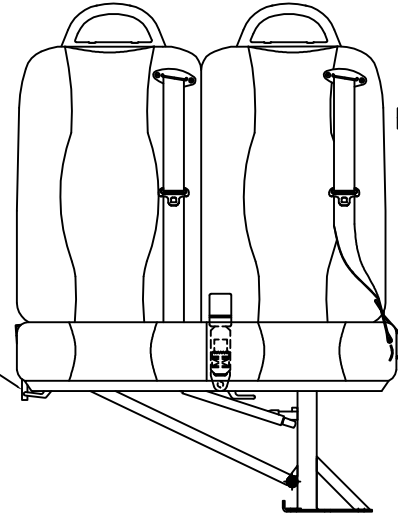
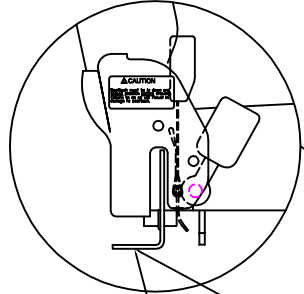
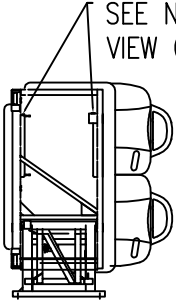

1. PULL LEVER UPWARD
2. FOLD SEAT FORWARD UNTIL IN LOCKED POSITION.
8. PULL LEVER UPWARD TO RAISE SEAT BACK. LIFT UNTIL LOCKED INTO POSITION.

7. PUSH HANDLE TO FOLD DOWN.
HOLD SEAT WHILE LOWERING.
PUSH DOWN UNTIL IN LOCKED POSITION.

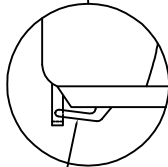
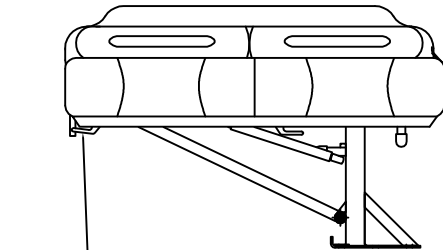

3. PUSH LEVER UPWARD
4. FOLD SEAT TOWARD WALL UNTIL IN LOCKED POSITION.

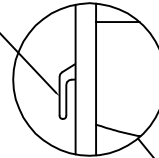

5. ROTATE TRUSS LOCK CLOCKWISE TO LOCK IN PLACE.
6. ROTATE COUNTERCLOCKWISE TO UNLOCK.

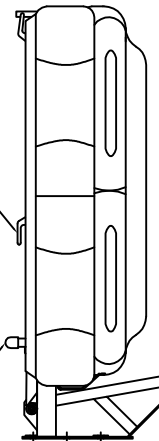

				Tolerance Unless Otherwise Specified				Material:		Freedman Seating Co.		4545 W. Augusta Chicago, IL 60651	
				FRAC. 1/X ±1/32				Specifications:		Part Name		INSTRUCTIONS, 3PT FOLDAWAY	
				DECIMAL .XX ±0.02"				Drawn by: RW		Date: 01/17/05		DO NOT SCALE DRAWING	
				ANGULAR ±1°						Drawing No.		56658	
				Rev. Level						Rev.		A	
A				RELEASE TO PRODUCTION				RW		1/05		4194	
Rev. Level				Description of Change				By		Date		ECN #	

DATE:

ORDER NUMBER: