

# FREEDMAN

# HANDI-FLIP



Are you interested in saving both time and money? The Freedman Seating *Handi-Flip Seat* offers convenience and quality at a price you can afford. Available as a single, double or triple passenger bench, the *Handi-Flip* has been designed with an easy to install, innovative connecting system allowing single units to be efficiently ganged together over any wheelwell for multiple passenger, perimeter seating applications. The infinitely adjustable legs provide flexibility and reduced installation time. The *Handi-Flip* locks in the upright position and measures less than 9" deep when folded up. Like all Freedman Seating products, the *Handi-Flip* meets all applicable Federal Motor Vehicle Standards for strength and safety, and can be made FMVSS 210 certified for seat belt applications.\* Quality built and economically priced, the Freedman *Handi-Flip Seat* has it all.

\* FMVSS 210 only applies to forward facing applications.

Not Just Seats



Seating Solutions™

THE FEATHER WEIGHT SERIES BY

**FREEDMAN**  
SEATING COMPANY

# FREEDMAN

# HANDI-FLIP

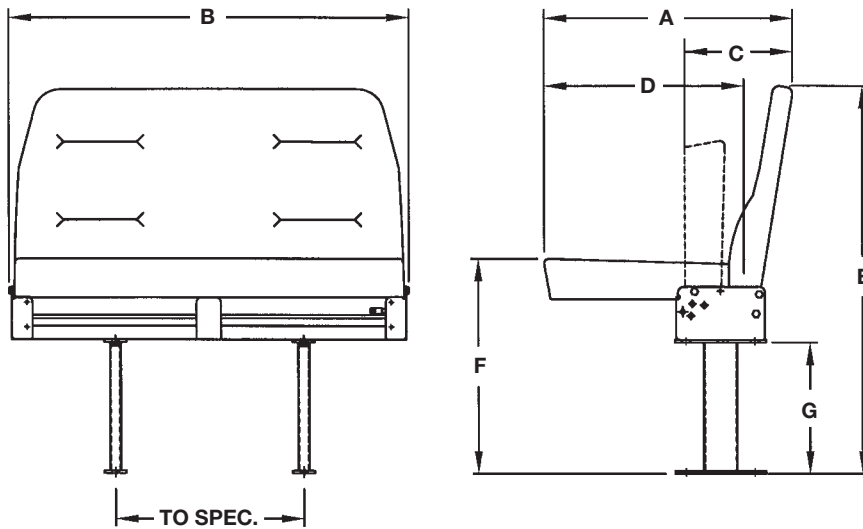

MODEL	WEIGHT	A*	B	C*	D	E	F	G**
Single Low-Back Handi-Flip	36¼ lbs.	21¾	18	8½	18	33¼	18	10¾
Double Low-Back Handi-Flip	54½ lbs.	21¾	35¾	8½	18	33¼	18	10¾
Triple Low-Back Handi-Flip	75¾ lbs.	21¾	53¾	8½	18	33¼	18	10¾

All sizes in inches.

\* Back cushion can be reclined an additional 2½" for increased comfort.

\*\* 12" available. (Add 1¼" to measurements E and F)

## Features

- Ergonomically correct seat and back
- Molded polyurethane back cushioning for long lasting support and comfort
- Less than 9" deep when folded up
- No gap between the seat and back cushion when folded down
- Seat height reflects the needs of the van and small bus industries
- All steel construction, no wood or plastic
- Locks in the upright position
- Innovative connecting system
- Infinitely adjustable bolt-on legs tall enough to clear any wheel well
- Flex-o-lator grid seat springs for even support
- Companion to the *Freedman Feather Weight Low Back seat*

## Options

- Black molded *U.S.Arms* or upholstered flip-up arms
- Padded grab rails (black or yellow)
- Vandal-resistant *AV Grab Rail*
- Mesh map pockets
- Vertical stitching
- FTA foam

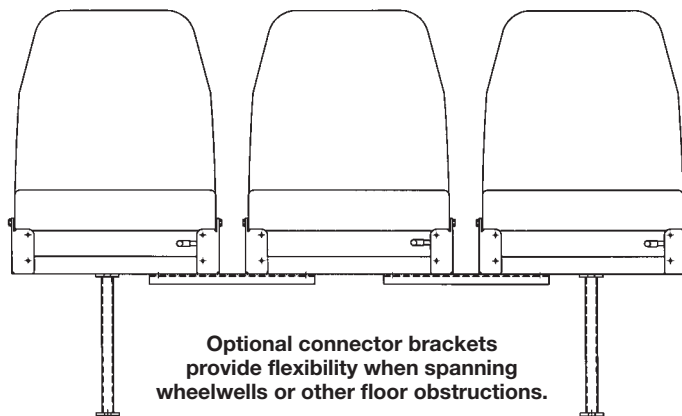

Not Just Seats



Seating Solutions™

THE FEATHER WEIGHT SERIES BY

**FREEDMAN**  
SEATING COMPANY

4545 W. Augusta Blvd., Chicago, IL 60651  
(773)524-2440 (800)443-4540 Fax: (773)252-7450

WWW.FREEDMANSEATING.COM

e-mail: sales@freedmanseat.com

We are constantly updating and improving our seats; therefore we reserve the right to change or modify specifications or materials without notice. All Freedman Seating Company seats meet or exceed FMVS standards.