

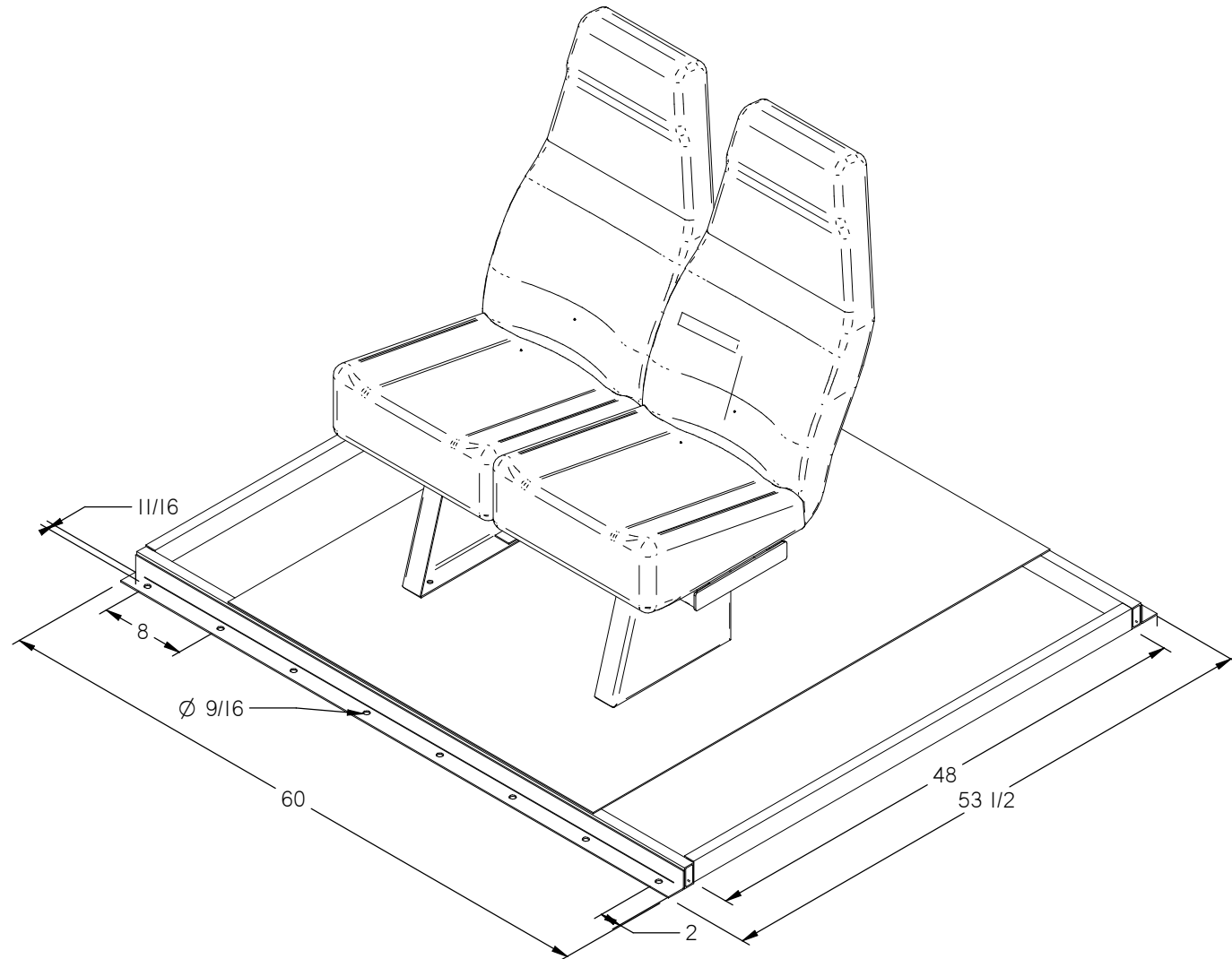

NOT TO BE USED, DISCLOSED OR REPRODUCED WITHOUT PERMISSION.
PROPERTY OF FREEDMAN SEATING COMPANY.

REV.	DATE	ECN	DESCRIPTION	BY	CHKD.	APPD.



Tolerances Unless Otherwise Specified:
 Fraction: 1/X +/- 1/32"
 Decimal: XXX +/- 0.02"
 XXX +/- 0.005"
 Angular +/- 1 Degree
 Unspecified Radii are 1/8"

SOLID EDGE HOME USE

DRAWING NAME: SECTION MOUNTING PLATFORM					
MATERIAL:	 Freedman Seating Co. 4345 W. Augusta Blvd Chicago, IL 60631			PROJECTION: 	
SPECIFICATION:	Author:	DATE	CHECKED	APPROVED	SUPERSEDES
	Alec Brennan	2/4/2011			
	SIZE: C	DRAWING No.			REV.
SCALE: NOT TO SCALE	BS	CODE	ISSUE DATE	SHEET: 1 of 1	

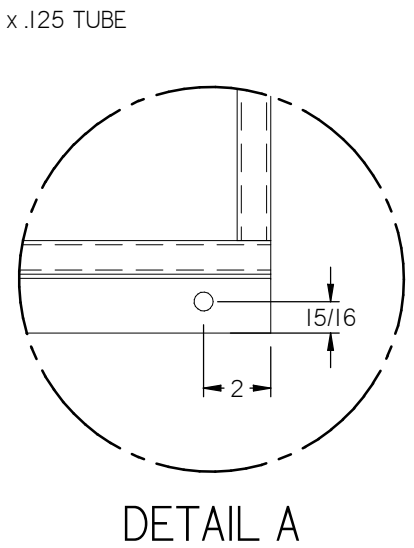
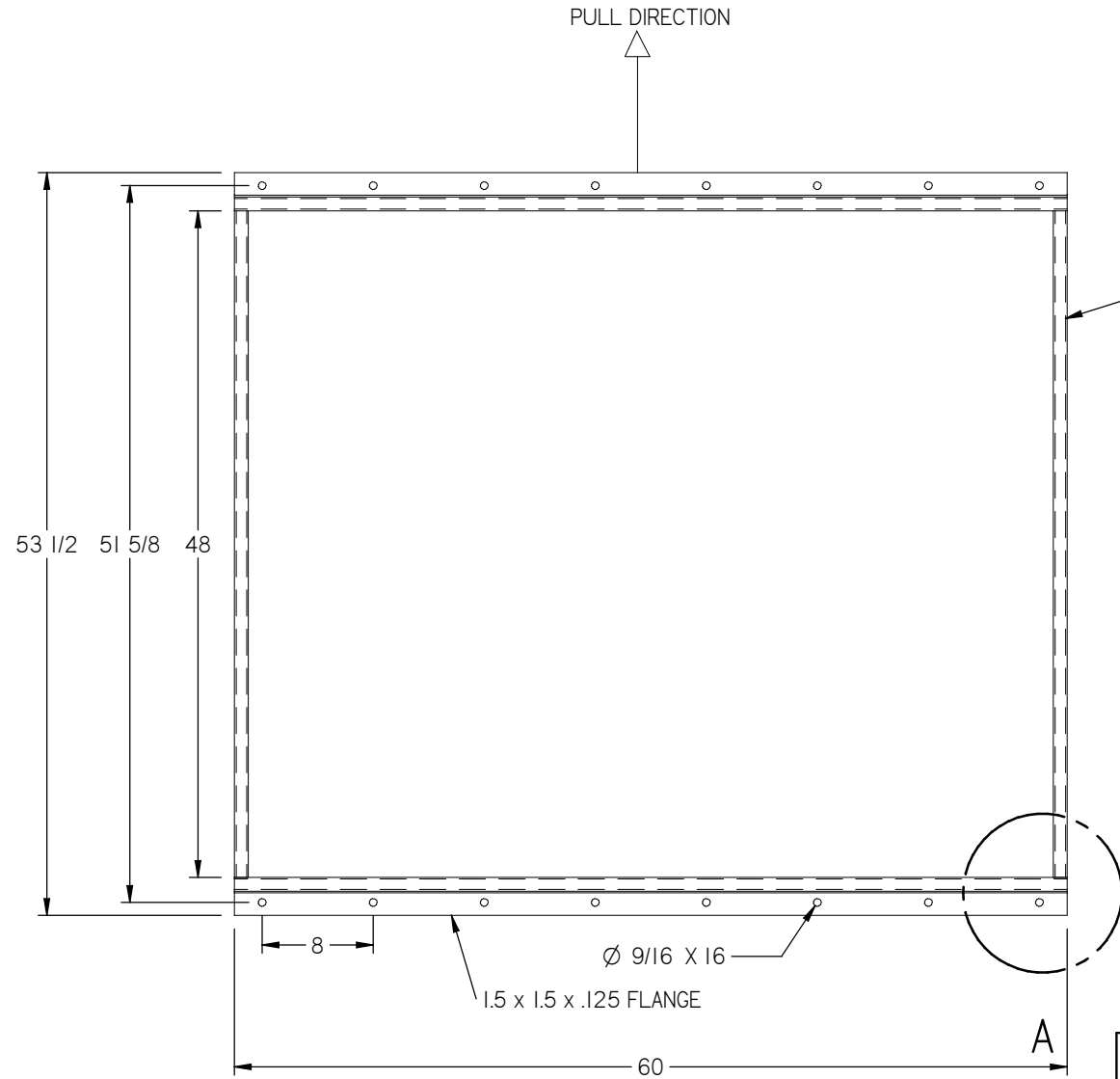

NOT TO BE USED, DISCLOSED OR REPRODUCED WITHOUT PERMISSION.
PROPERTY OF FREEDMAN SEATING COMPANY.

REV.	DATE	ECN	DESCRIPTION	BY	CHKD.	APPD.
------	------	-----	-------------	----	-------	-------



Tolerances Unless Otherwise Specified:
 Fraction: 1/8 +/- 1/32"
 Decimal: .XXX +/- 0.02"
 .XXXX +/- 0.005"
 Angular +/- 1 Degree
 Unspecified Radii are 1/8"

SOLID EDGE HOME USE

DRAWING NAME: SECTION MOUNTING PLATFORM					
MATERIAL:		 Freedman Seating Co. 4345 W. Augusta Blvd Chicago, IL 60651		PROJECTION: 	
SPECIFICATION:		Author:	REF:	SUPERSEDES:	
By: AB	DATE 2/4/2011	CHECKED:	APPROVED:		REV.
SIZE C	DRAWING No.:				
SCALE: NOT TO SCALE	BSM	CODE:	ISSUE DATE:	SHEET: 1 of 1	