

FREEDMAN SHIELD DRIVER SEATS

Shield
Rigid
Seat



**NOW
AVAILABLE**

Sport Seat
Upgrade



Shield
Recliner
Seat



LeMans Adjustable Arm



Sustainable Seating Solutions
Freedman Seating Company

Not Just Seats



Seating Solutions™

FREEDMAN
SEATING COMPANY

FREEDMAN SHIELD DRIVER SEATS

Shield Rigid Seat

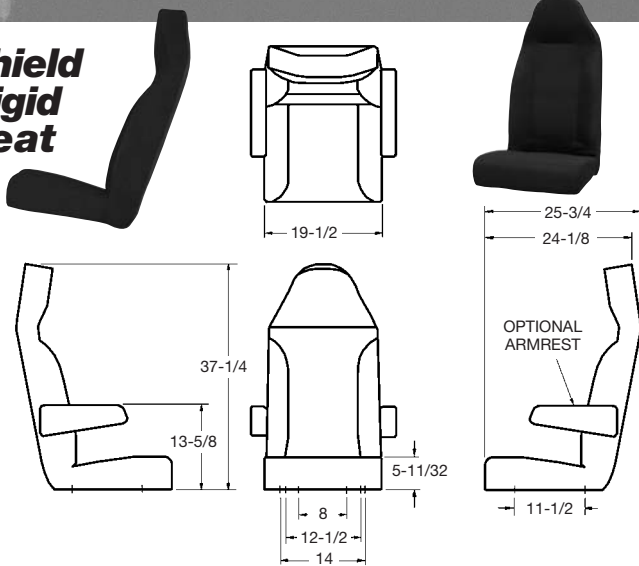

Shield Recliner Seat

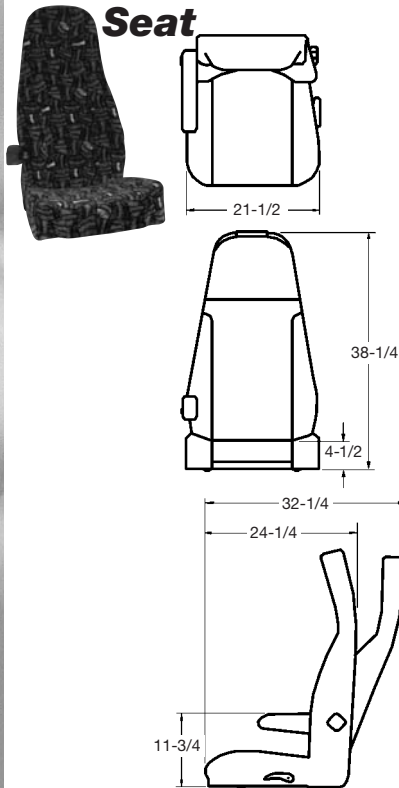

Sport Seat

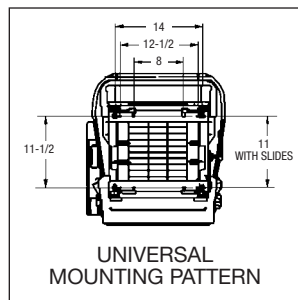
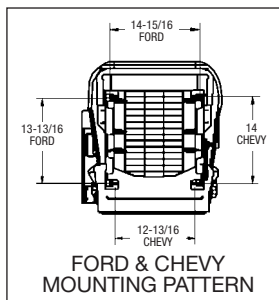
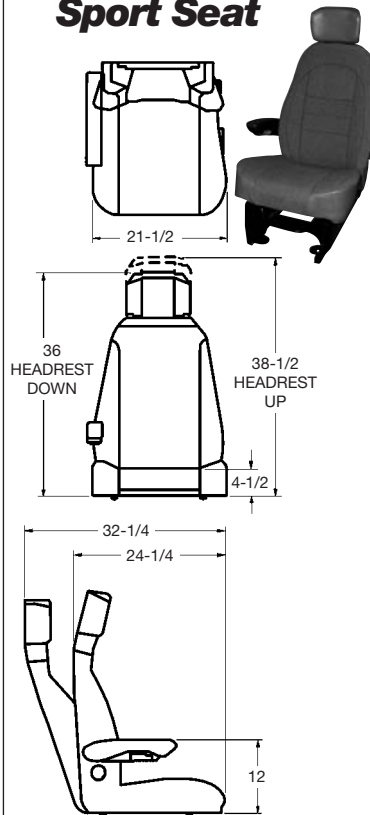

MARKETS



DELIVERY TRUCK



BUS



VAN



MARINE



SPECIALTY

We are constantly updating and improving our seats; therefore we reserve the right to change or modify specifications or materials without notice. All Freedman Seating Company seats meet or exceed FMVS standards.

Shield Rigid Seat

Standard features:

- Designed and tested to comply with all applicable FMVSS requirements including 202A headrest standard
- Taller and wider headrest with decreased backset
- “Cushier” headrest for dynamic impact headrest absorption
- Automotive grade 4-spring seat flex-o-later for even load support and long life
- J-clip upholstery fastening for quick change out with no special tools
- High quality molded polyurethane seat and back cushions
- Universal mounting holes to fit Freedman Seating pedestals and most aftermarket bases

Rigid Seat optional features:

- Flip arms: US Arm, AMA
- Mesh map pocket
- Vertical stitching
- Wide array of fabrics and vinyls
- 4-position adjustable upholstered or wide upholstered lumbar support
- S3 Bio Cushions
- Fore/Aft slide tracks

Shield Recliner and Sport Seats

Standard features:

- Designed and tested to comply with all applicable FMVSS requirements including 202A headrest standard
- Taller and wider headrest with decreased backset
- “Cushier” headrest for dynamic impact headrest absorption
- Mesh map pocket
- Automotive grade 4-spring seat flex-o-later for even load support and long life
- J-clip upholstery fastening for quick change out with no special tools
- High quality molded polyurethane seat and back cushions

Recliner Seat additional standard features:

- 4-position adjustable lumbar-LH lever (RH lever on copilot)
- RH Shield arm
- Heavy duty recliner mechanism
- Mounting brackets to fit Ford E-Series and Chevy cutaway seat delete bases

Recliner Seat optional features:

- Vertical stitching (not for Sport)
- Wide array of fabrics and vinyls
- FTA foam
- S3 Bio Cushions
- Universal mounting kit to fit Freedman Seating pedestals and aftermarket bases
- Fore/Aft slide tracks (not for Ford or Chevy seats), required for universal mounting

Sport Seat additional standard features:

- Infinitely adjustable 4-way lumbar (up/down and in/out)
- RH LeMans arm



Sustainable Seating Solutions
Freedman Seating Company

Not Just Seats



Seating Solutions™

FREEDMAN
SEATING COMPANY

4545 W. Augusta Blvd., Chicago, IL 60651
(773)524-2440 (800)443-4540 Fax (773)252-7450
WWW.FREEDMANSEATING.COM
e-mail: sales@freedmanseat.com