

FREEDMAN DRIVER SEATS

The FSC Ford Seat

Model year 1997 and after

The FSC Ford Seat mounts directly to the Ford OEM base and slides. No changes or alterations to the Ford OEM parts are required (when chassis is ordered seat delete).

This seat is also available as the *Chevy Econo* or the *FSC Econo Seat*.

Sport Seat

Available for most any make and model bus

The Freedman Sport Seat is the ultimate in drivers seat comfort and value. The armrest and headrest can be adjusted to fit any body type, while the adjustable lumbar supplies exceptional support. European styling and vertical stitching provide a first class look. The Freedman Sport Seat has it all. The Sport Seat is available as the *Ford Sport Seat*, *Chevy Sport Seat* or the *FSC Sport Seat*.

Not Just Seats



Seating Solutions™

FREEDMAN
SEATING COMPANY

an ISO 9001:2000 certified company

FREEDMAN DRIVER SEATS

The FSC Ford Seat

Model year
1997 and
after

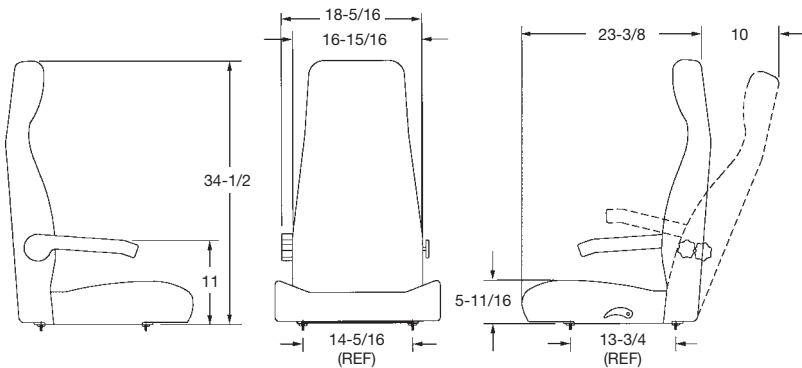
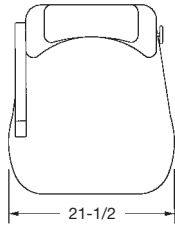

Sport Seat

Available for
most any make
and model bus

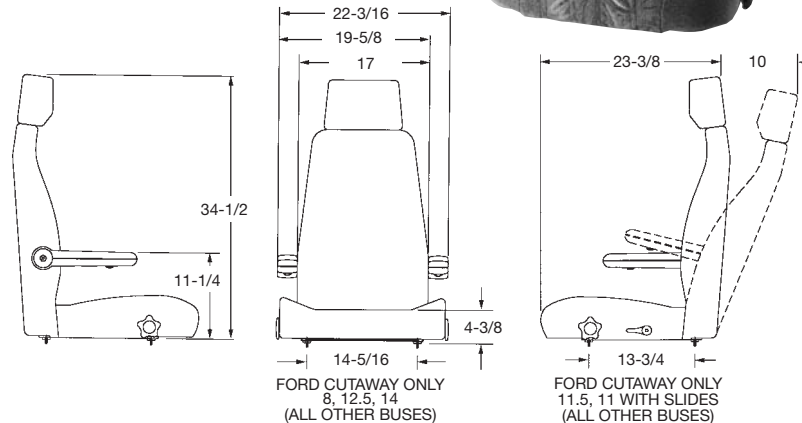
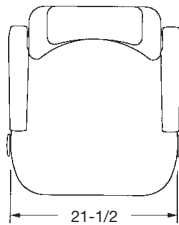

We are constantly updating and improving our seats; therefore we reserve the right to change or modify specifications or materials without notice. All Freedman Seating Company seats meet or exceed FMVS standards.

The FSC Ford Seat

Standard features include:

- Reclining backrest
- Adjustable lumbar support
- Mesh map pocket
- Right hand flip-up U.S. Arm (left for co-pilot seat)
- High back design for neck support
- Meets Ford H-point requirements
- Meets all applicable Federal Motor Vehicle Safety Standards

Standard options include:

- A wide variety of vinyl and cloth fabrics
- Vertical stitching
- FTA foam
- Chevy Econo Seat
- FSC Econo Seat for aftermarket bases
- 6" fore and aft slides (not for Ford or Chevy seats)

Sport Seat

Standard features include:

- Reclining backrest
- Mid back with adjustable headrest
- 4 way adjustable lumbar (knobs on back cushion)
- LH recliner lever (RH lever on co-pilot)
- Adjustable flip arm (1, 2 or no arm(s) depending on bus)
- Mesh map pocket
- Vertical stitching and European styling
- Meets all applicable Federal Motor Vehicle Safety Standards

Standard options include:

- Mounting points to accommodate most any bus (conforms to Ford H point and all applicable FMVS standards and bolts easily to Ford E-series seat delete base).
- A wide variety of vinyl and cloth fabrics
- Chevy Sport Seat version
- FSC Sport Seat version for aftermarket bases
- 6" fore and aft slides (not for Ford or Chevy seats)
- FTA foam
- The **Relaxor**® massage system with built-in heater. The pattern, location, speed and intensity of the massage is controlled with the touch of a finger from a conveniently located wand. The Relaxor® can reduce driver's fatigue and increase alertness.

Not Just Seats



Seating Solutions™

FREEDMAN
SEATING COMPANY

an ISO 9001:2000 certified company

4545 W. Augusta Blvd., Chicago, IL 60651
(773)524-2440 (800)443-4540 Fax (773)252-7450
WWW.FREEDMANSEATING.COM
e-mail: sales@freedmanseat.com