

# FREEDMAN

## The CitiPro TRANSIT COLLECTION

When you want to win, go with a Pro! **The CitiPro**

Lightweight, strong, safe and practically vandal proof sums up the CitiPro. Ideal for buses and rail cars, the CitiPro's modular construction creates the most maintenance free seating solution in its class!

**The CitiPro** also has something you don't expect in a heavy-duty transit seat... comfort. Each seat is made with the rider in mind. The ultra-thin backrest provides exceptional hip-to-knee room while the ergonomic design comfortably supports the rider. The CitiPro is the perfect seat for short and medium distance trips and can be upholstered with or without padding and in any vinyl or cloth. European styling and pleasing aesthetics make the CitiPro a seat riders want to sit in.



Shown with optional stainless steel back and grab rail.

Not Just Seats



Seating Solutions™

**FREEDMAN**  
SEATING COMPANY

# FREEDMAN

# The CitiPro

## TRANSIT COLLECTION

Every CitiPro comes with the service, on-time delivery and after-the-sale support bus builders, distributors and operators have come to expect from Freedman Seating Company.

### Construction and Features

- The CitiPro is manufactured with custom formed aluminum extrusions for superior strength and significant weight savings. The seat and back panels are made from injection molded plastic for comfort, weight and durability.
- Seat and back inserts can be easily removed for cleaning or replacement.
- The "T" leg and/or cantilever frame can be made of powder-coated carbon or stainless steel.
- The base frame can be customized to accommodate almost any wall track or mounting system.
- The CitiPro is completely modular, any part of the seat can be replaced in minutes.

### Options

The CitiPro is available with the following options:

- Energy absorbing molded thermoplastic steel grab handles
- Your choice of AV (Anti-Vandal) inserts with KEVLAR®
  - Non Padded
  - Padded
  - Padded with FTA foam
- FTA (low smoke docket 90 foam) or HR polyurethane per FMVSS 302
- Your choice of vinyl or fabric (polyester, olefin or wool)
- Flip seats (forward or aisle facing)
- Hinged rear row
- Stainless steel back panel

Not Just Seats



Seating Solutions™

**FREEDMAN**  
SEATING COMPANY

4545 W. Augusta Blvd., Chicago, IL 60651  
(773) 524-2440 (800) 443-4540 Fax (773) 252-7450  
WWW.FREEDMANSEATING.COM  
e-mail: sales@freedmanseat.com

We are constantly updating and improving our seats; therefore we reserve the right to change or modify specifications or materials without notice. All Freedman Seating Company seats meet or exceed FMVSS standards.

### CitiPro



Shown with standard plastic back.

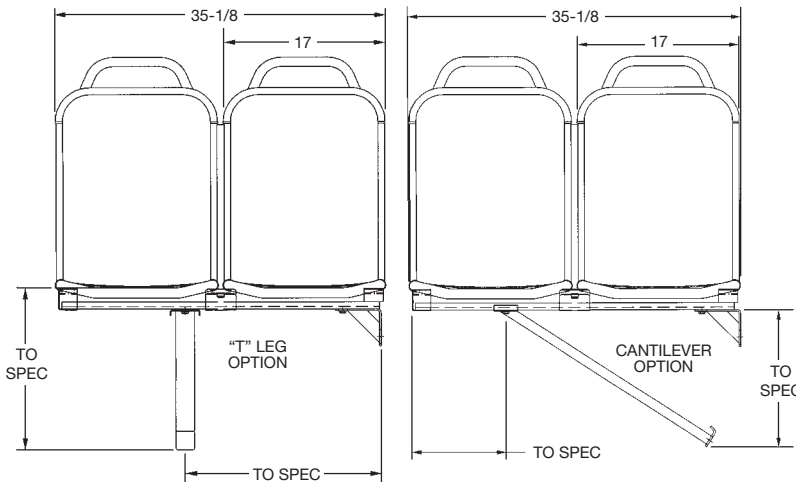
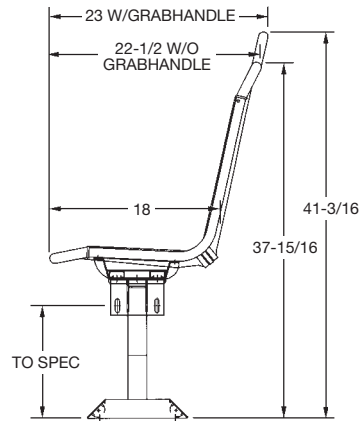

### CitiPro Flip

