



FSTL Test Prep List.

Ted Kolar tedk@freedmanseat.com Pre-test contact. Test Requests, Test Setup, testing plan, vehicle section verification. vehicle section shipping and receiving.

Dave O'Malley davido@freedmanseat.com During test contact. Questions regarding test standards, test procedures, deviations to requests, modifications to vehicle and testing plan.

Miguel Flores miguelf@freedmanseat.com During testing contact. Performing Tests, questions regarding test standards, test procedures, & conducting tests.

Dave Klopp davek@freedmanseat.com Manager of Test Lab

Ordering Seats for Testing :: Ted Kolar tedk@freedmanseat.com

Requirements before Scheduling Tests:

1. "Form 016-In-vehicle Seat Test Request" and "Form 014-FSTL Work Order Packet Cover Page" must be filled out completely for *each* position in the vehicle.
2. A listing of all hardware in the installation of *each* seat along with torque specifications.
3. Drawings of the Van with seating positions clearly marked.
4. Vans dimensions cannot exceed 180" long by 102" wide by 90" tall and cannot exceed 4,200 lbs [shipping weight]. The front end of some vehicle may need to be cut behind the driver's seat to reduce the length of the vehicle. Vehicles shall have no glass, windshield, dashboard, gas tank, or engine. Vehicle shall have a frame. Vehicles shall be sent ready to test.
5. All seats are to be pre-ordered at least 4 weeks prior to testing through FSC sales department [Ted Kolar tedk@freedmanseat.com] and installed by the builder in the buck prior to shipping to FSTL.
6. Account must be current with FSC for scheduling and performance of test.
7. We strongly suggest and encourage an engineering representative be present at all in-vehicle tests. Even with all of the experience FSTL has with in-vehicle testing, there are issues that arise during setup. There is no substitute for customer's insight into their vehicle.

Vans should be scheduled to arrive at Freedman the Friday before testing begins. Do not send earlier. After completion of tests, bucks shall be scheduled, by the customer, for return to customer within 1 week. A bill of lading shall be provided for the pickup of the vehicle by the customer.



Notes:

Seats do not require seatbelts.

Sales Dept. is to ship seats to FSTL for inspection prior to shipping to customer.

FMVSS 207/210 test. Seat assemblies do not require paint, covers, or foam.

FMVSS 225 test. [Child Restraint Seats] Seats are complete Assemblies (paint not required).

Shipping Address:

Freedman Seating Test Lab

4544 W Chicago Ave

Chicago, IL 60651

NOT TO BE USED, DISCLOSED OR REPRODUCED WITHOUT PERMISSION.
PROPERTY OF FREEDMAN SEATING COMPANY.

REV.	DATE	ECN	DESCRIPTION	BY	CHKD.	APPD.
------	------	-----	-------------	----	-------	-------

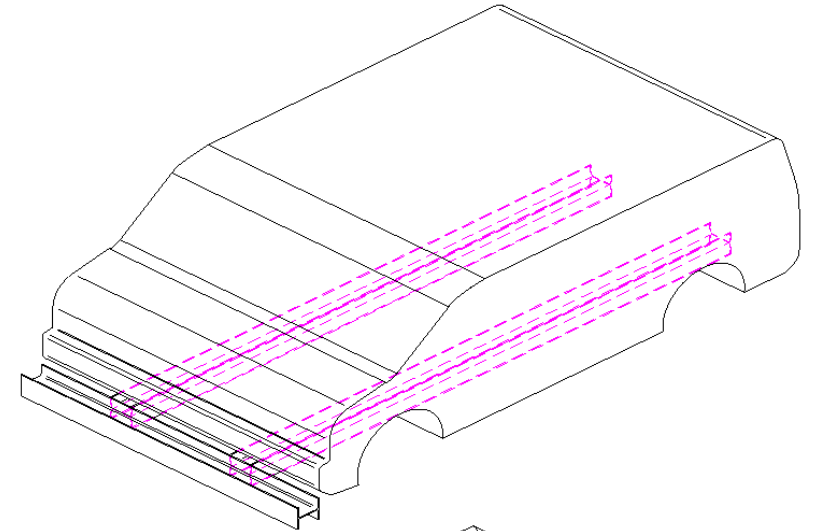
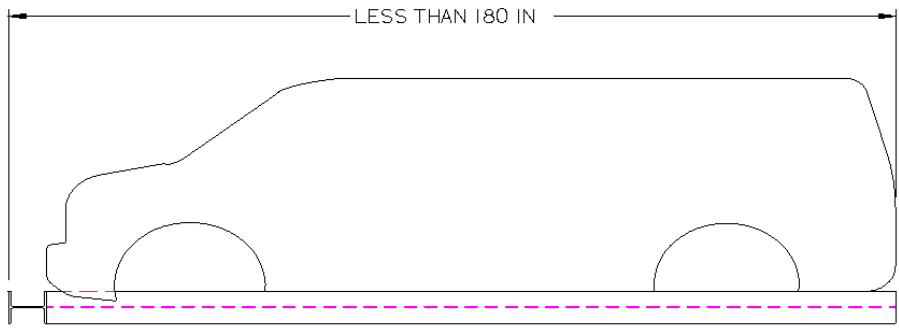

FRONT SECTION CAN BE CUT OFF TO ACHIEVE LENGTH

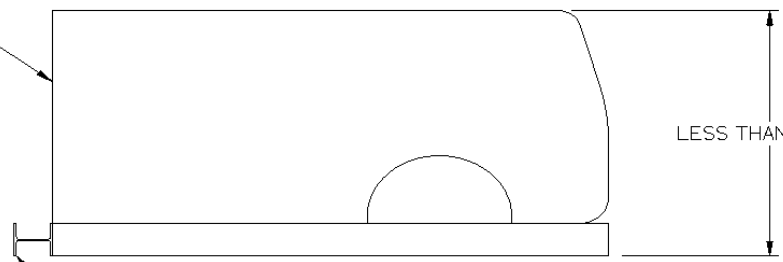

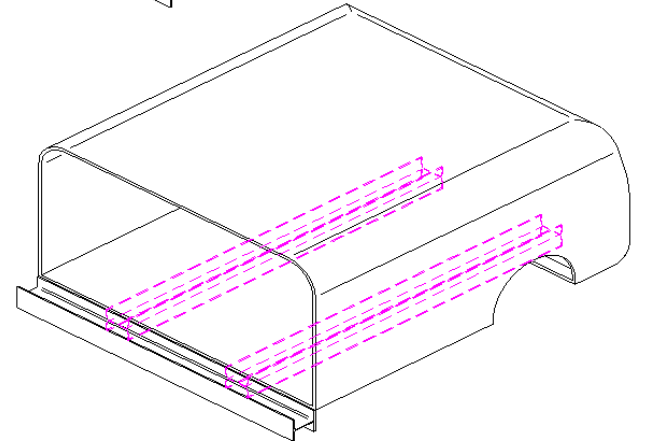

FLUSH MOUNTED FRONT FRAME BUMPER



- NOTES:
- 1) NO GLASS
 - 2) NO WINDSHIELD
 - 3) NO DASHBOARD
 - 4) NO GAS TANK
 - 5) NO ENGINE
 - 6) VEHICLE ON OEM FRAME
 - 7) CANNOT EXCEED 4,200 LBS

Tolerances Unless Otherwise Specified:
 Fraction: 1/32"
 Decimal: XXX +/- 0.02"
 XXXX +/- 0.005"
 Angular +/- 1 Degree
 Unspecified Radii are 1/8"

DRAWING NAME:					
MATERIAL:	 Freedman Seating Co. 4848 W. Augusta Blvd Chicago, IL 60629			PROJECTION 	
SPECIFICATION:	DESIGNED BY: Jeremyk DATE: 4/7/2011	CHECKED BY: DATE: 	APPROVED BY: 	SUPERSEDES: 	REV. #:
SCALE:	C DRAWING NO.		PART NO.	GROUP NO.	SHEET 1 of 1
SCALE: NOT TO SCALE					