



FSTL Test Prep List.

Any Questions please contact any of the following.
Phone 773-524-2440

Ted Kolar tedk@freedmanseat.com Pre-test contact. Test Requests, Test Setup, testing plan, vehicle section verification. vehicle section shipping and receiving.

Dave O'Malley davido@freedmanseat.com During test contact. Questions regarding test standards, test procedures, deviations to requests, modifications to vehicle and testing plan.

Miguel Flores miguelf@freedmanseat.com During testing contact. Performing Tests, questions regarding test standards, test procedures, & conducting tests.

Dave Klopp davek@freedmanseat.com Manager of Test Lab

Ordering Seats for Testing :: Ted Kolar tedk@freedmanseat.com

Requirements before Scheduling Tests:

1. "Form 016-In-vehicle Seat Test Request" and "Form 014B-FSTL Work Order Packet Cover Page External" must be filled out completely for *each* position in the vehicle.
2. A listing of all hardware in the installation of *each* seat along with torque specifications.
3. Drawings of the buck with seating positions clearly marked. Test Buck to be placed on two rigid "I Beams" approximately 6 in. to 8 in. tall, spaced about 3 ft. to 6 ft. apart, and extending out about 1 ft. Buck dimensions cannot exceed 156" long by 102" wide by 90" tall and cannot exceed 4,200 lbs [shipping weight].
4. All seats are to be pre-ordered at least 4 weeks prior to testing through FSC sales department [Ted Kolar tedk@freedmanseat.com] and installed by the builder in the buck prior to shipping to FSTL.
5. Account must be current with FSC for scheduling and performance of test.
6. We strongly suggest and encourage an engineering representative be present at all in-vehicle tests. Even with all of the experience FSTL has with in-vehicle testing, there are issues that arise during setup. There is no substitute for customer's insight into their vehicle.

Bucks should be scheduled to arrive at Freedman the Friday before testing begins. Do not send earlier. After completion of tests, bucks shall be scheduled, by the customer, for return to customer within 1 week. A bill of lading shall be provided for the pickup of the vehicle by the customer.



S5 of FMVSS No. 210 for side-facing seats , the specified force would be applied in the direction that the seat faces in a vertical plane perpendicular to the longitudinal centerline of the vehicle.

Notes:

Seats do not require seatbelts.

Sales Dept. is to ship seats to FSTL for inspection prior to shipping to customer.

FMVSS 207/210 test. Seat assemblies do not require paint, covers, or foam.

FMVSS 225 test. [Child Restraint Seats] Seats are complete Assemblies (paint not required).

Shipping Address:

Freedman Seating Test Lab

4544 W Chicago Ave

Chicago, IL 60651

REV.	DATE	ECN	DESCRIPTION	BY	CHKD.	APPD.
------	------	-----	-------------	----	-------	-------

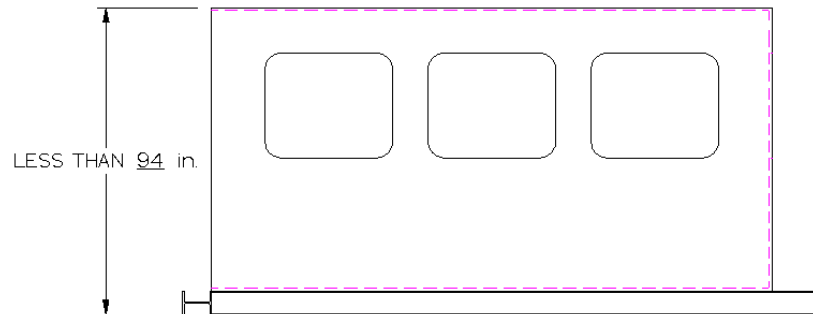
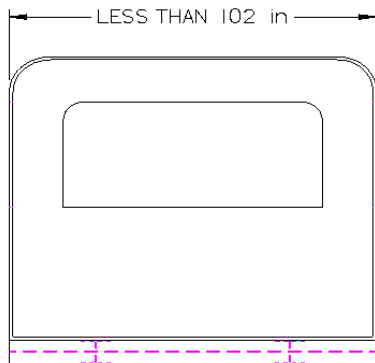
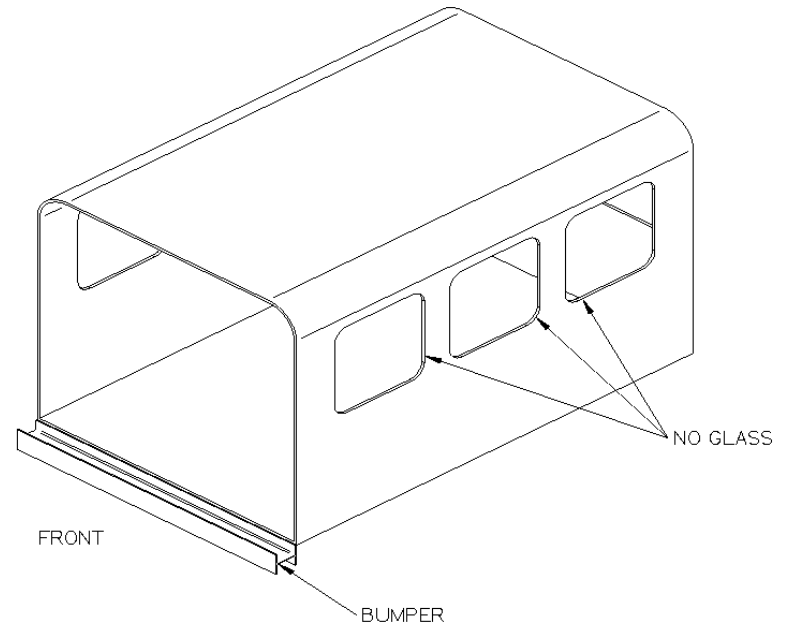
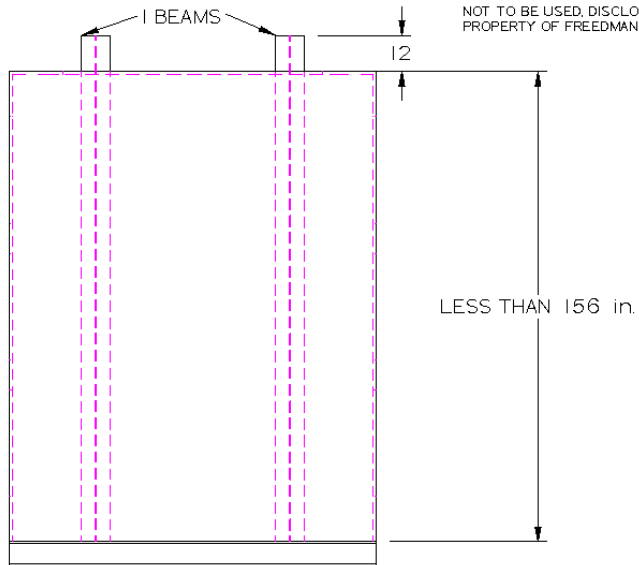

NOT TO BE USED, DISCLOSED OR REPRODUCED WITHOUT PERMISSION.
PROPERTY OF FREEDMAN SEATING COMPANY.



- NOTES:
1) NO GLASS
2) WEIGHT LIMIT : 4,200 LBS

Tolerances Unless Otherwise Specified:
Fraction 1/32"
Decimal XXX +/- 0.02"
XXXX +/- 0.005"
Angular +/- 1 Degree
Unspecified Radii are 1/8"

SOLID EDGE HOME USE

DRAWING NAME:						
BUCK REQUIREMENTS						
MATERIAL:		 Freedman Seating Co. 4848 W. Augusta Blvd Chicago, IL 60681			PREPARED BY: 	
SPECIFICATION:		DATE:	CHANGED:	APPROVED:	REV.:	
		AB	2/17/2011			
		SEE	DRAWING NO.:			
		C				
SCALE:	REV:	ECN:	TRUCK QTY:	PAGE: 1 of 1		
NOT TO SCALE						